



PRODUCT SPECIFICATIO

5mm ROUND YELLOW LED LAMP
DLHI.05MM.R020.RO15

Approved By	Checked By	Prepared By

5mm ROUND YELLOW LED LAMP

Features

- ※ High intensity
- ※ Reliable and rugged
- ※ Low current requirement
- ※ IC compatible

Description

The YELLOW Lamps are made With AlInGaP/Sapphire chip and Water clear epoxy resin.

Package Dimensions

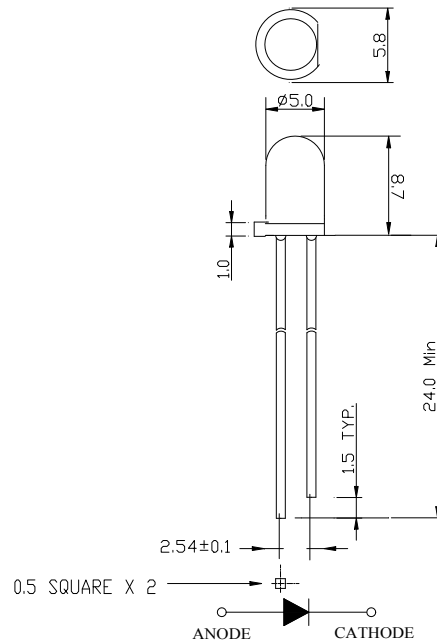

Part NO.	LED chip		Lens Color
	Material	Emitting Color	
	AlInGaP /Sapphire	YELLOW	Water clear

Notes:

1. All dimensions in mm tolerance $\pm 0.2\text{mm}$ unless otherwise noted.
2. An epoxy meniscus may extend about 1.5mm down the lead
3. Burr around bottom of epoxy may be 0.5mm max.

5.0mm ROUND YELLOW LED LAMP

Absolute Maximum Ratings(Ta=25°C)

Parameter	Symbol	Rating	Unit
Power Dissipation	PD	80	mW
Forward Current (DC)	IF	30	mA
Peak Forward Current(Pulse width≤0.1msec duty≤1/10)	IFP	100	mA
Reverse Voltage	VR	5.0	V
Electro-Static-Discharge	ESD	2000	V
Operation Temperature Range	Topr	-25to+85	°C
Storage Temperature Range	Tstg	-40to+100	°C
Lead Soldering Temperature(3.0mm from body) for 5 seconds		260	°C

Typical Electrical and Optical Characteristics(Ta=25°C)

Parameter	Symbol	Condition	Min.	Typ.	Max.	Unit
Luminous Intensity	Iv	If=20mA	5000		7000	mcd
Forward Voltage	Vf	If=20mA	1.8		2.4	v
Wave length	WLD	If=20mA	585		595	nm
Reverse Current	Ir	Vr=5v			10	uA
Viewing Angle	2 θ 1/2	If=20mA		15		deg

Light Emitting Diode

5.0mm ROUND YELLOW LED LAMP

Typical Electrical / Optical Characteristics Curves

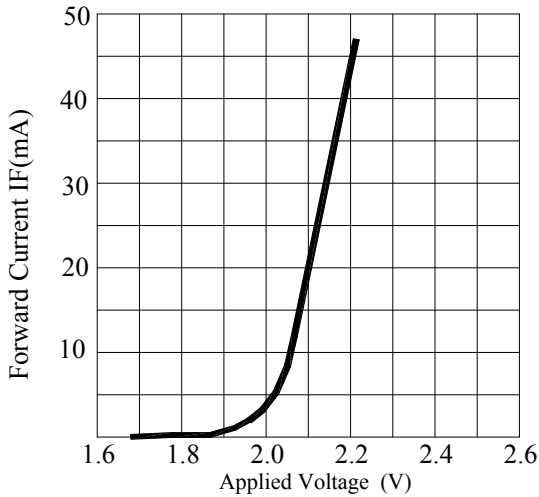

FORWARD CURRENT VS. APPLIED VOLTAGE

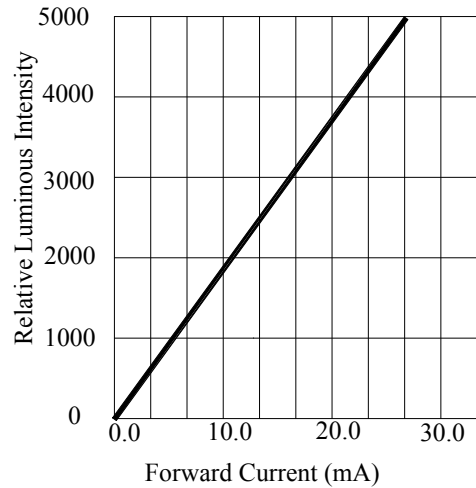

FORWARD CURRENT VS. LUMINOUS INTENSITY

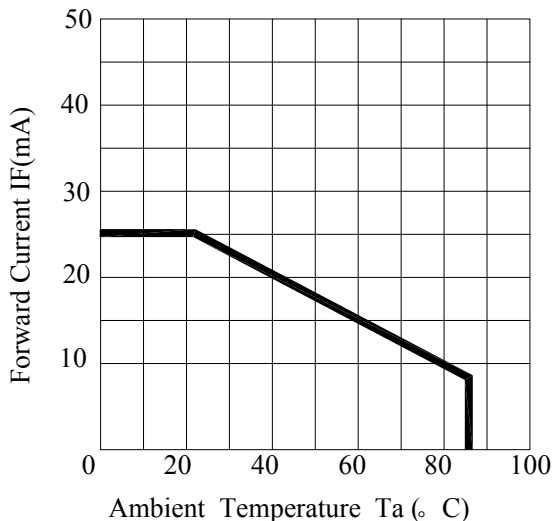

AMBIENT TEMPERA TURE VS.FORWARD CURRENT

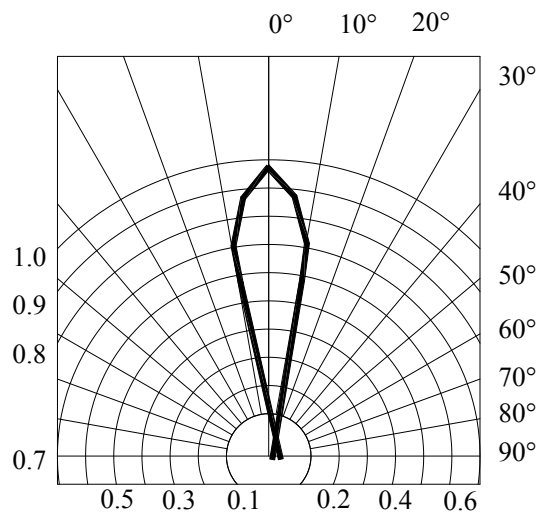

RADIATION DIAGRAM

Please read the following notes before using the datasheets:

Light Emitting Diode

- 一、 If you need pin to be bent because of design:
 - 1、 The lead frame can only be bent or cut when it is 3mm or above away from the colloid.
 - 2、 The molding of material if needed must be finished before soldering, while molding the PIN is not allowed to be the fulcrum and must be finished by professional with fixture;
 - 3、 Lead frame molding must guarantee that the space between lead is same as Circuitry Board
 - 4、 High voltage static electricity could be produced while molding the Pin because of vibration friction of machine, so the machine must be reliably grounding (By way of blowing ion fan to eliminate static electricity)
- 二、 Soldering Condition:
 - 1、 Do not conduct the electricity while soldering the LED
 - 2、 Do not forces while the lead are in the heating condition.
 - 3、 Max. soldering condition:

Manual soldering:	Wave soldering
Max. Power of iron: 30 W	Highest Warm up temperature: 120℃
Highest Temperature: 300 ℃	Highest Dip soldering temperature 260 ℃
Longest Soldering time: 3 seconds	Longest Dip soldering time: 5 seconds
Soldering position:	Dip soldering position:
3mm above from the colloid base	3mm above from the colloid base.
- 三、 Anti-static notice :
 - 1、 All the LED instrument must be grounding
 - 2、 All the people, who are possible to touch the LED must wear anti-static wrists and gloves.
 - 3、 Any LED damaged by static will appear some bad characters, such as , leakage current increase, Static forward voltage decrease.
- 四、 Over current protection:
 - 1、 Add protective resistor in series to make it work stable.
 - 2、 Resistor value formula: $R = (VCC - VF) / IF$ (VCC is power supply voltage, VF is LED drive voltage, IF is forward current.)
- 五、 Electrical performance test and application:
 - 1、 While testing VF, brightness and wavelength, the current must be set with 20mA; test VR, IR must be set with 10uA; Test IR, VR must be set with 5V.
 - 2、 Whiling testing and using LED, LED must be provided with the same current and tested by constant current source, and then we can make sure the brightness and consistency of other characteristics
 - 3、 LED used under the environment temperature between -30 ℃ ~+60 ℃
 - 4、 When the products are well sorted, please do not use it to the same products with different classes or bag Numbers (Marked in the label), so as to avoid the color and brightness difference. If it is necessary to use with mix bags, please use strictly according to the sequence of bag number. (Not recommended to use like this)